

# WMF Cup dispenser planning information

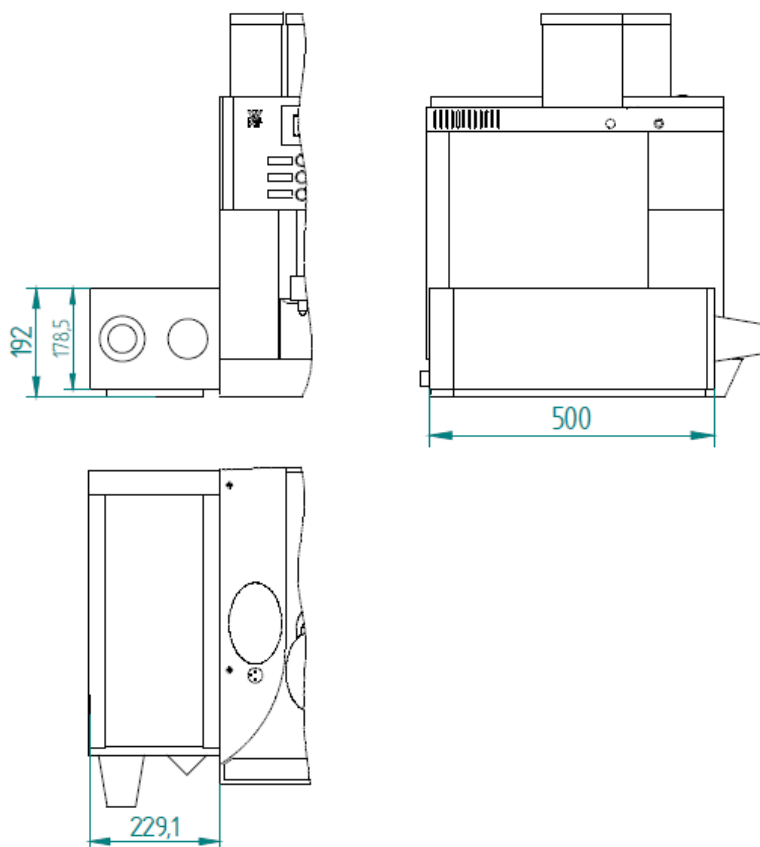

Dimension and weight	Width Height Depth Weight	230 mm 192mm 500 mm Approx. 5 kg
Miscellaneous	Space for paper cup stacks 2x 390 mm Possible paper cup diameter 60 – 90 mm	
Installation surface / water spray	The device must be placed and leveled on a horizontal, sturdy, water-resistant, and heatproof base. The device must not be cleaned using a water jet. The device must be installed where it is protected against water spray. The device must not be located on a surface that is sprayed or cleaned with a water hose, steam jets, steam cleaner, or similar devices.	

For more information as the instruction manual , safety data sheets and certificates , see:  
<https://coffeeconnect2.wmf.com>

All information refers to coffee machines/ equipment as standard version. Individual solutions can differ from the standard version.